



TDF TRAY SEALERS

TDF | 1650-1900



Brand new and revolutionary fully automatic Traysealer mod. TDF1650 & TDF1900: for the packaging of plastic, cartboard & aluminium preformed trays, with on-reel plastic films lids, carton lids & reclosing-cap application option. Machine frame completely realized in stainless steel: metal sheets obtained by laser cutting, electrically welded holding elements.



	MAX. TRAYS DIMENSION					
TDF 1650	320 206	320 151	320 118	320 95	320 80	320 68
TDF 1650-D	150 206	150 151	150 118	148 95	80 80	68 68
TDF 1900	320 290	320 214	320 168	320 137.7	320 115	320 99
TDF 1900-D	150 290	150 214	150 168	148 137.7	115 115	99 99

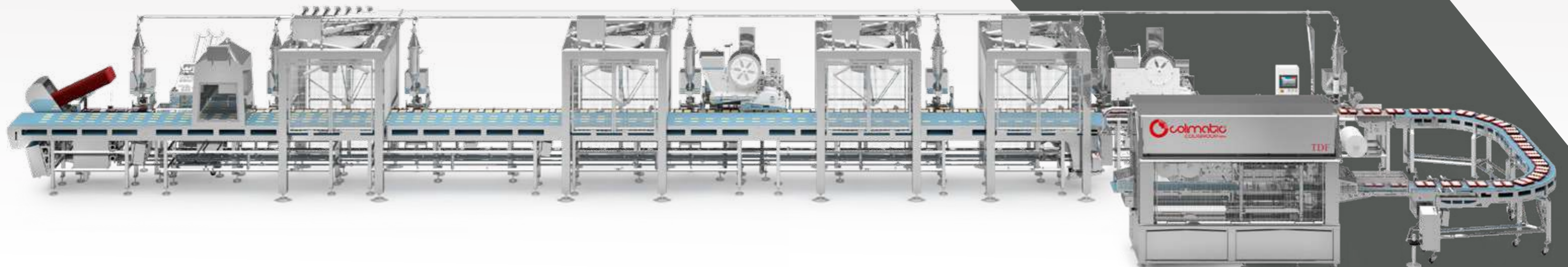
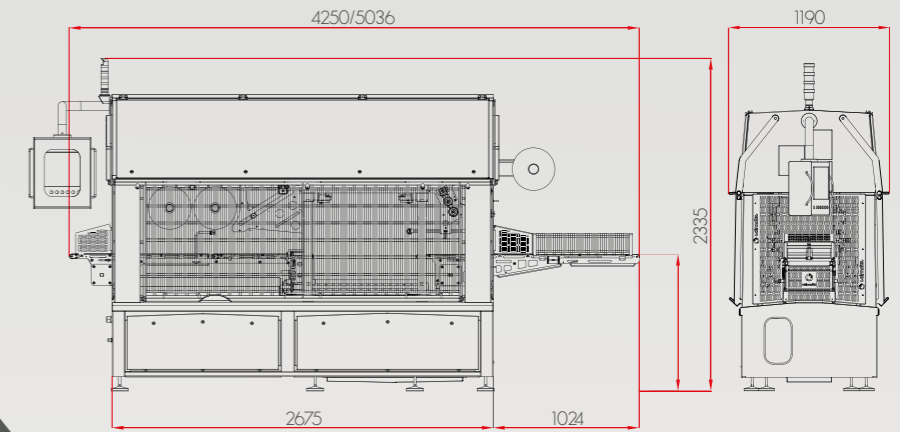

THERMOSEALING LINE MOD. TDF1650-1900



NEW USER-FRIENDLY HMI

Which allows an easier access to all machine functions, by **simplifying** the settings, the machine activation and system check.

EXTREME ENERGY SAVING

The configuration with shared DC Bus allows the energy exchange between the axis, **reducing the energy wasting** caused by the dynamic braking resistances. This will sensibly reduce (down to 40%!) the amount of energy required. (KERS - Kinetic Energy Recovery System).



TDF | 1650-1900

HYGIENICAL FEATURES

Sloping machine surfaces, TIG continuous welding and motors strategically protected and positioned, Will grant the **highest possible hygiene levels!**



SCRAPS REWINDER

Rewinder with pneumatic expansion and increased stroke, to allow the scraps rewinding on both carton or directly on the roll. The group is controlled by clutch with adjustable strength to adapt it to every kind of film. The motor is positioned inside the electrical cabinet.

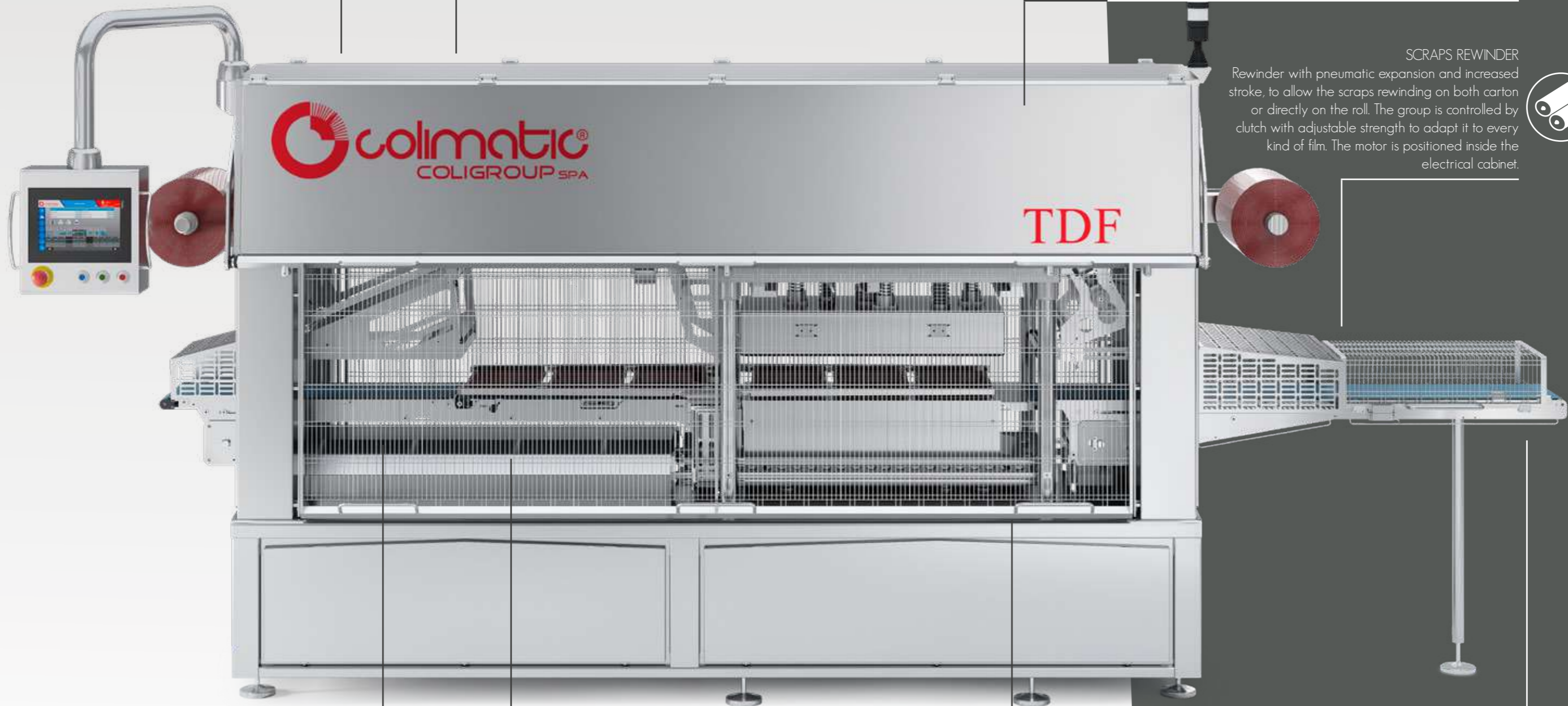
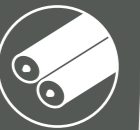

SEALING STATION

Servomotor controlled Lifting mechanism of the sealing station, this is managed by the same cam used for the pushers. Sealing strength to be set on the HMI.



PUSHER GROUP

Moved by nr. **2 Servomotors controlled by electronic cam** for trays taking, their positioning under the sealing mould and discharge of sealed trays. Their motor is positioned inside the machine cabinet.



BRUSHLESS MOTORS

All machine motion controlled by **Brushless motors**. These, through an electronic cams connection of the moving components, allow more flexibility in terms of films used and speed control, according to the products to be packed.



INLET BELT

Servomotor controlled positioning system, for trays **correct positioning** at machine entrance. Made of **Stainless steel**, it is equipped with fast removal unlock system, to ease cleaning operations: no tools needed for belt handling.

TDF | 1500



The fully automatic cup thermosealing line mod. TDF 1500 is a unique solution that combines **automatic tray** loading, product feeding, data printing, and aroma-saving lid applicator with a compact design. On top of that, the multi-cavity chain advancing movement allows this machine to reach **higher production capacity**.

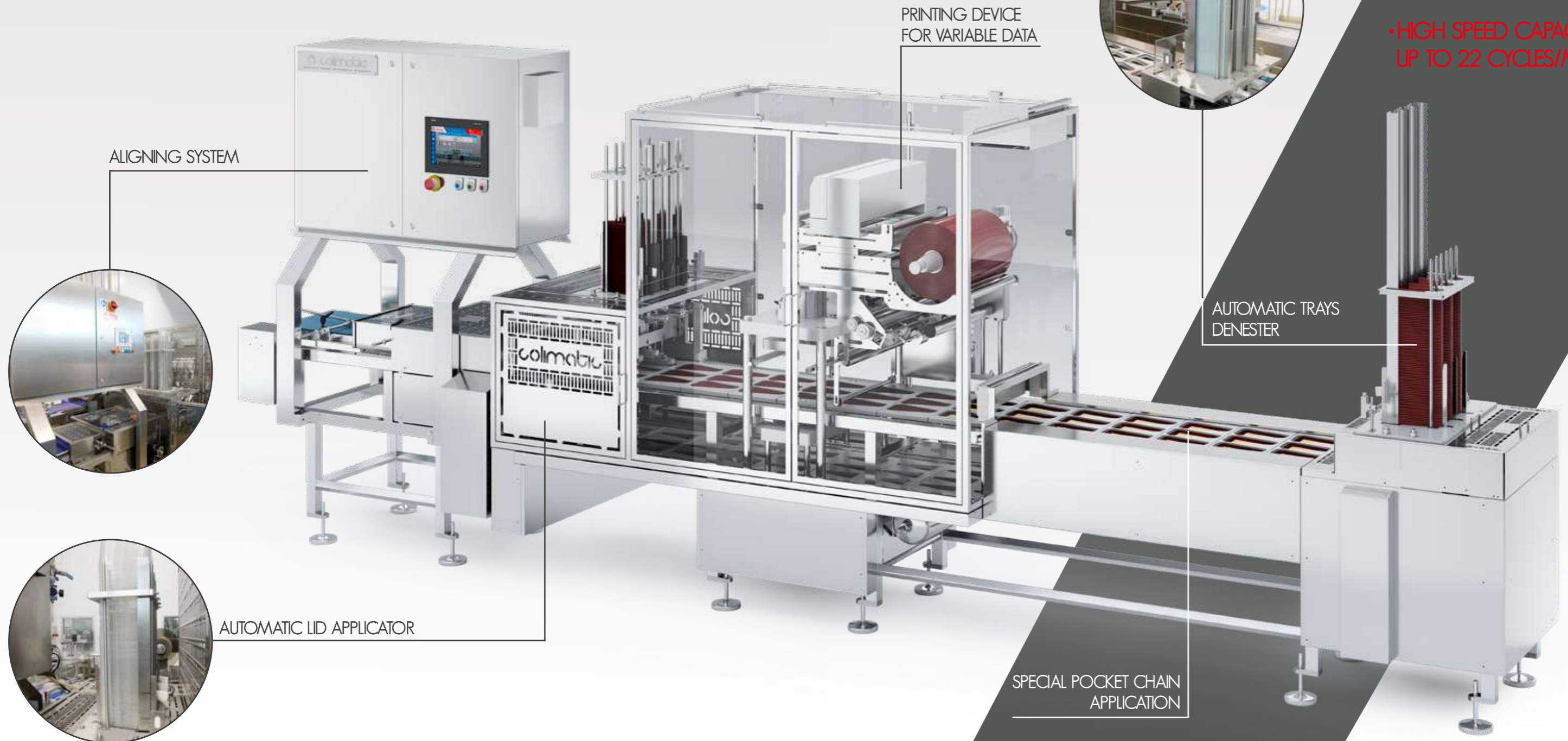

TDF | 1000

Automatic trayssealing mod. TDF 1000 for medium production outputs available only sealing, vacuum, modified atmosphere (MAP) in gas flush or vacuum+gas and SKIN. This **flexible model**, thanks to its modular structure, can also be equipped with **one, two or three sealing stations** simultaneously increasing considerably the output capacity.

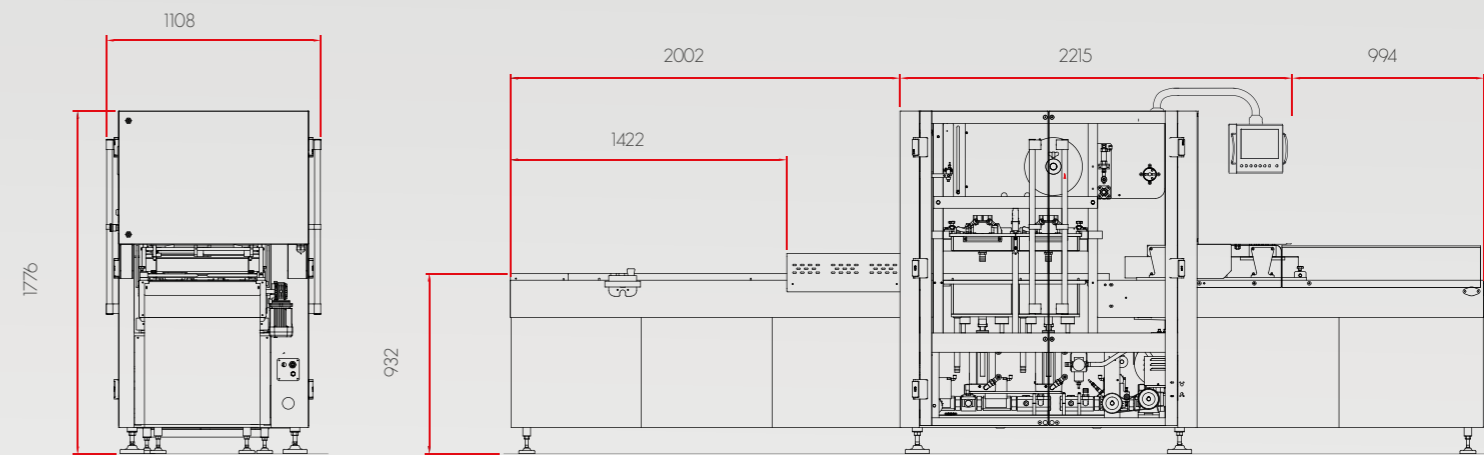

MAX. TRAYS DIMENSION			
TDF 1000	480	275	275
	225	275	275
	1435	275	275
	75	275	275



TDF | 1000 E

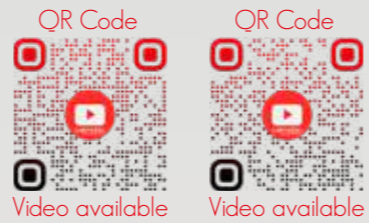

Automatic traysealing machine mod. TDF 1000 E for medium production outputs, only sealing or MAP packaging options.

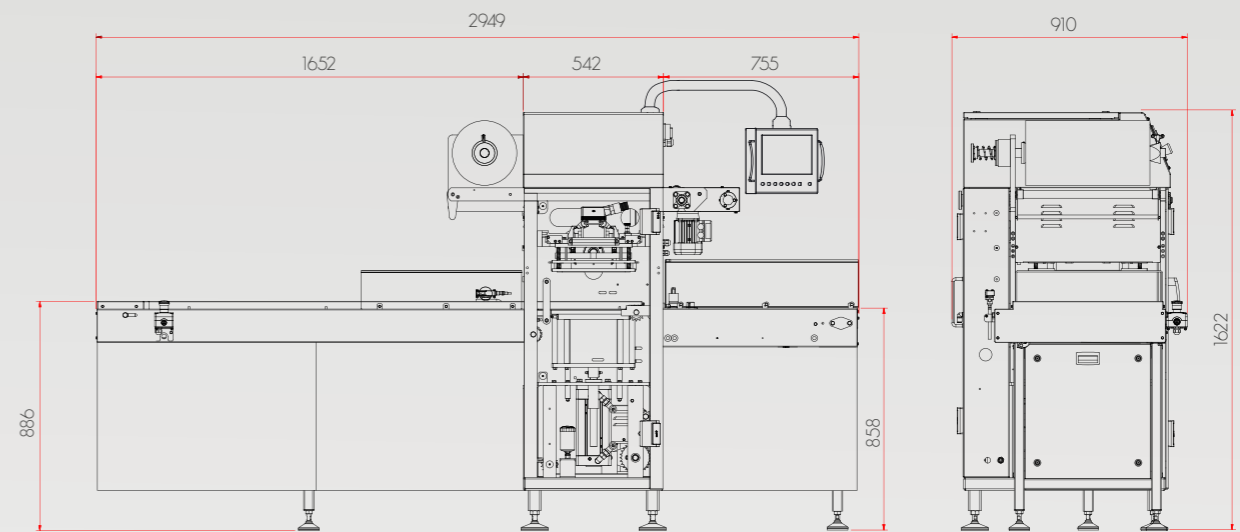

MAX. TRAYS DIMENSION			
TDF 1000 E	400	275	180
	120	275	80

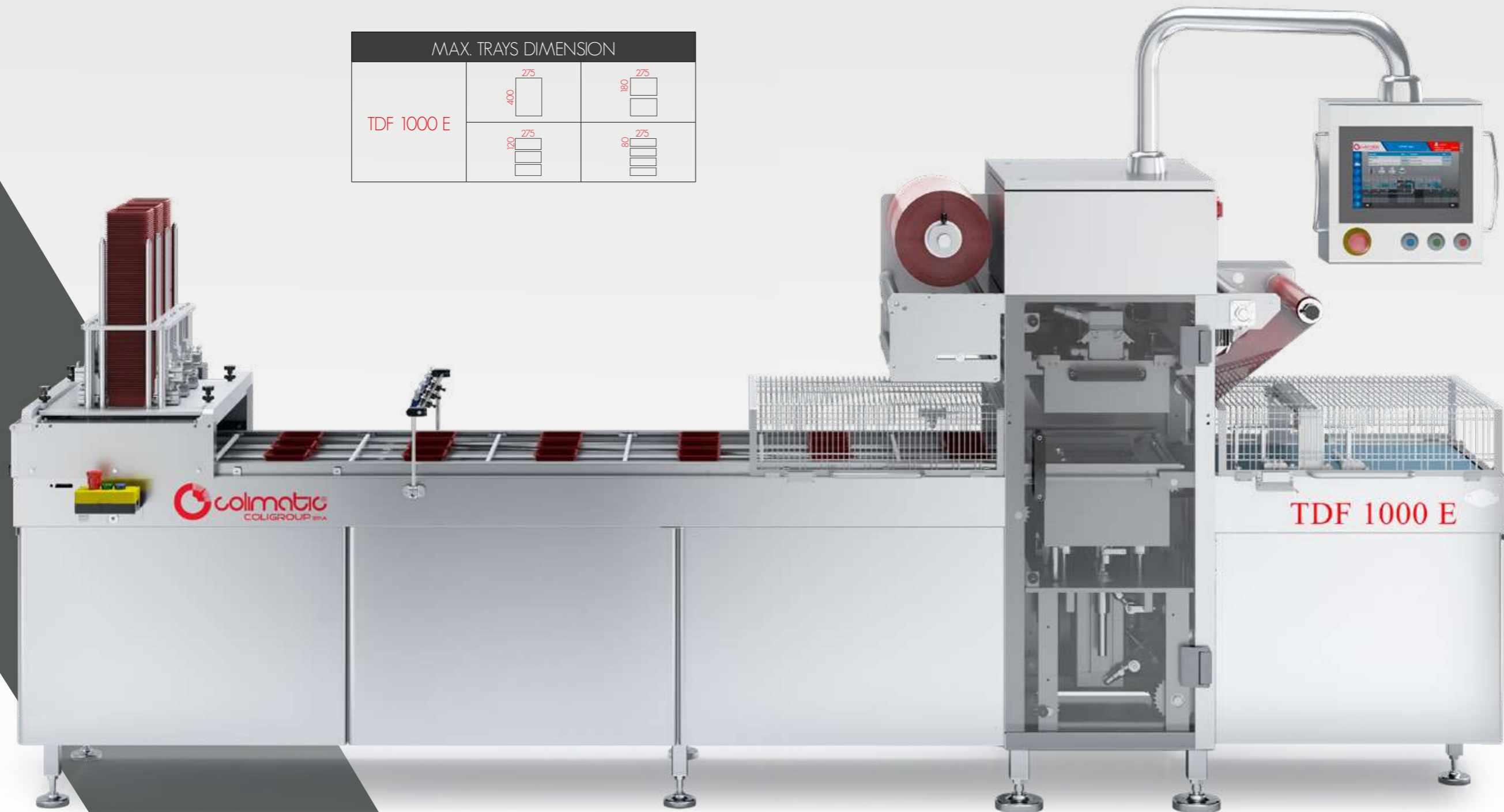

TDF | 500

Semi-Automatic traysealing machine mod. TDF 500 for small production outputs, only sealing or MAP packaging options.

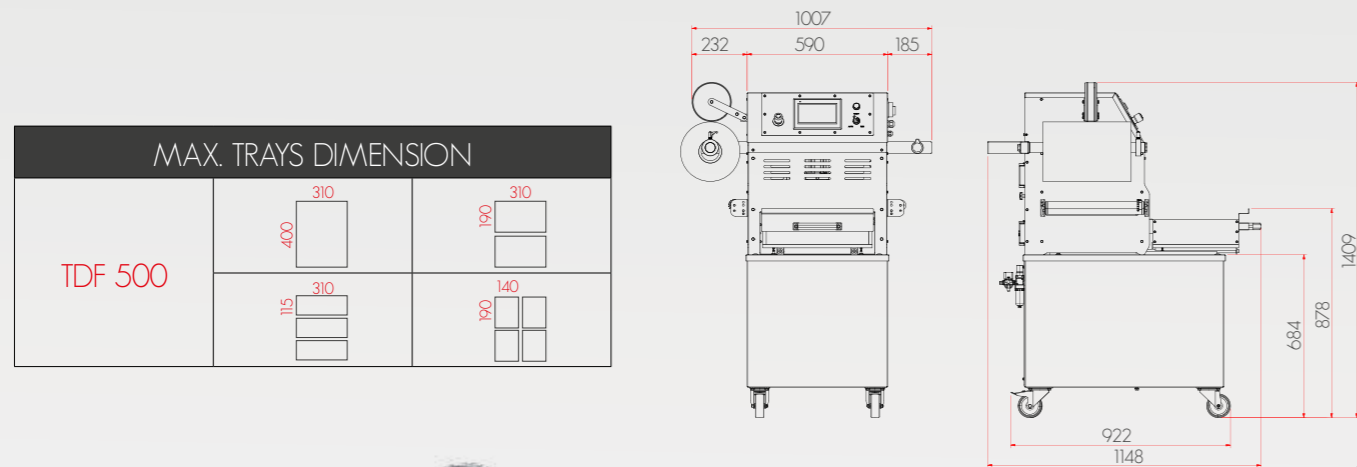

TDF | 500 SA

Semi-automatic traysealing machine mod. TDF500 SA with rotary die set table to increase productivity. Suitable to small production output for the packaging under vacuum, modified atmosphere (MAP) or SKIN with premade trays.

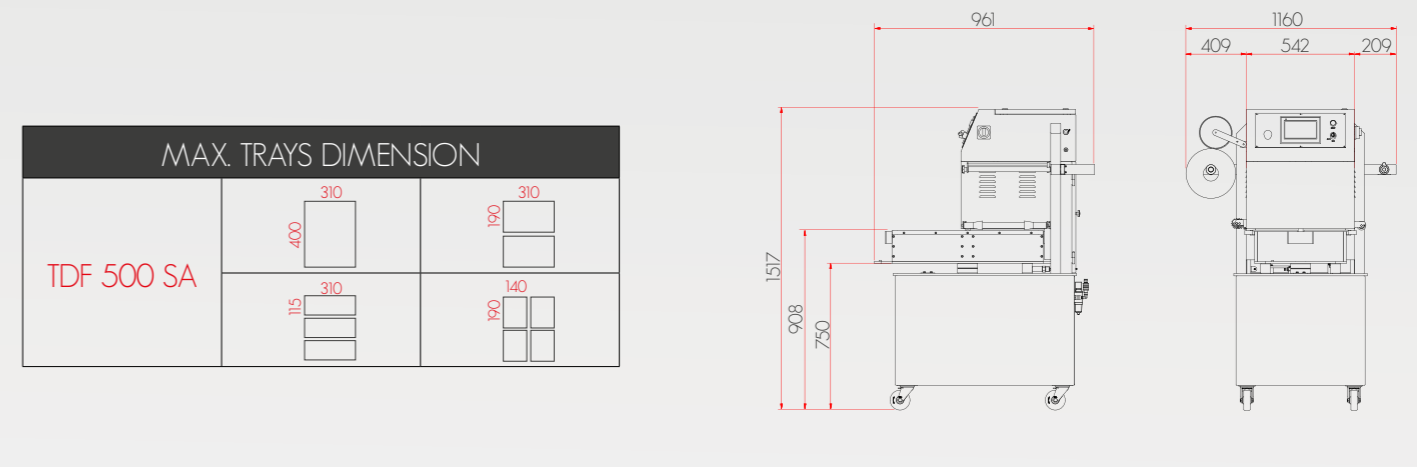

TDF | ACCESSORIES

- ALIGNING SYSTEMS
- AUTOMATIC LOADING SYSTEM FOR PRODUCTS
- AUTOMATIC WEIGHER DOSING UNIT
- AUTOMATIC BAD PRODUCT DISCHARGE
- AUTOMATIC UD POSITIONING SYSTEM
- BOOSTER VACUUM PUMP
- CHECKWEIGHERS
- COOLING SYSTEM WITH CHILLER
- DOSING UNIT MONOPORTION BUTTER
- DOSING UNIT FOR LIQUID AND CREAMY PRODUCTS
- DICED PRODUCTS DOSING SYSTEM
- HEATED DIE SET TROLLEY
- HOTFOIL INK-JET/THERMAL TRANSFER PRINTER
- LABELLERS
- LID APPLICATOR
- MULTIPLE DE-NESTING SYSTEM
- METAL DETECTOR AND XRAY CONTROL
- PICK&PLACE LOADING SYSTEM
- ROBOT LOADING SYSTEM
- ROBOT PICK&PLACE
- SYNCHRONIZATION UNIT BETWEEN DOSER AND MACHINE
- SAUCES DOSING SYSTEMS
- TWIN-REEL HOLDERS
- TRAY DE-NESTING SYSTEM

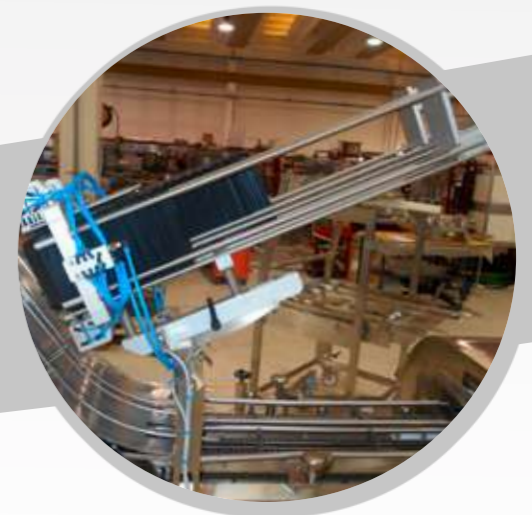
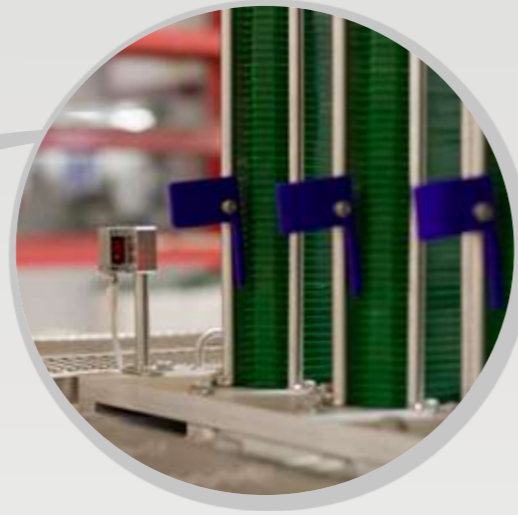

ITALIAN SOUL



GLOBAL ATTITUDE

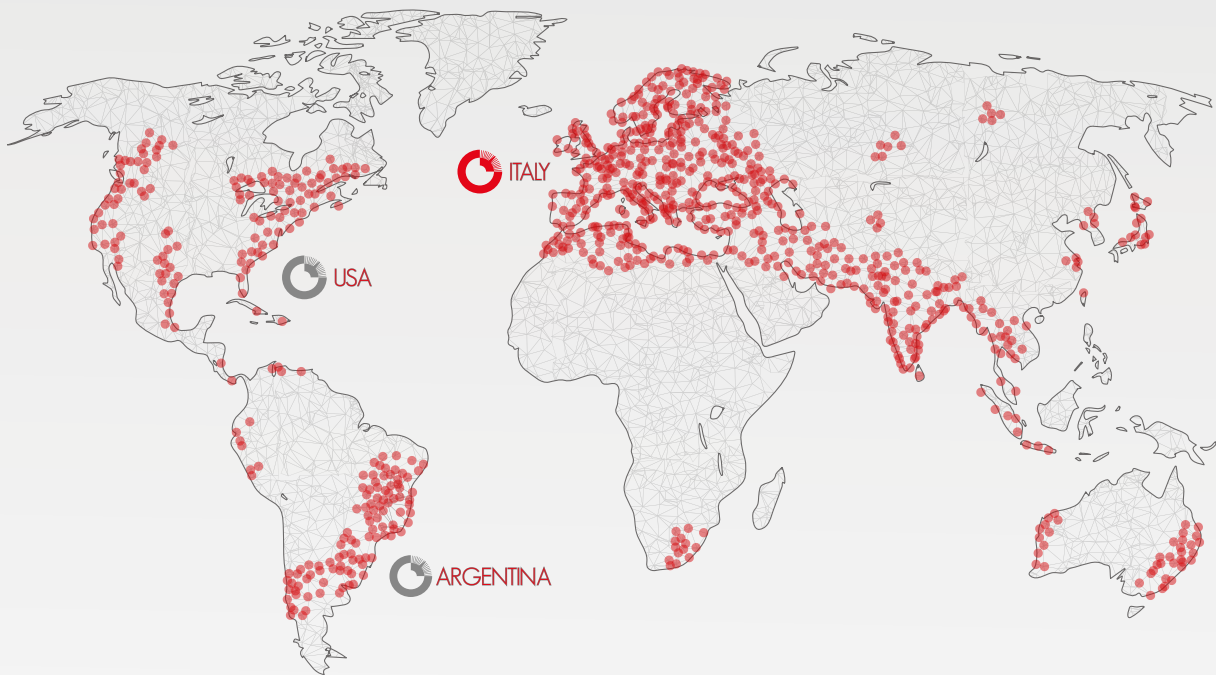

SMALL
ENOUGH TO LISTEN
BIG ENOUGH
TO SERVE!



COLIGROUP S.p.A Via del lavoro A, 9 25032
CHIARI (BS) Italy
Phone - 39 030 7000761/2/3
Fax - 39 030 713370
Email: info@colimatic.com www.colimatic.com